

Liste de pièces			
ARTICLE	QTE	NUMERO DE PIECE	MATIERE
1	1	Pied	Aluminum
2	1	Bati	Aluminum
3	2	Support essieu	Laiton (jaune doux)
4	1	cylindre	Aluminum
5	1	Chemise	Laiton
6	1	Cylindre refroidisseur	Acier
7	2	Support balancier	Aluminum
8	1	Deplaceur	Aluminum
9	1	Fond deplaceur	Aluminum
10	1	Axe balancier	Stub collé Loctite
11	2	Roulement 4 x 9 x 2.5	
12	1	Tige deplaceur	Acier
13	1	Entretoise	Laiton
14	1	Piston	Aluminum
15	1	Bielle piston	Laiton
16	1	Balancier	Laiton
17	1	Balancier2	Laiton
18	2	Entretoise balancier	Laiton
19	1	Bielle deplaceur	Laiton
20	2	Maneton	Laiton
21	1	Axe maneton	Stub collé Loctite
22	1	Essieu 1	Stub collé Loctite
23	1	Bielle balancier	Laiton
24	2	Axe balancier bielle	Stub collé Loctite
25	1	Axe bielle tige deplaceur	Stub collé Loctite
26	1	Essieu 2	Stub collé Loctite
27	1	Volant	Aluminum

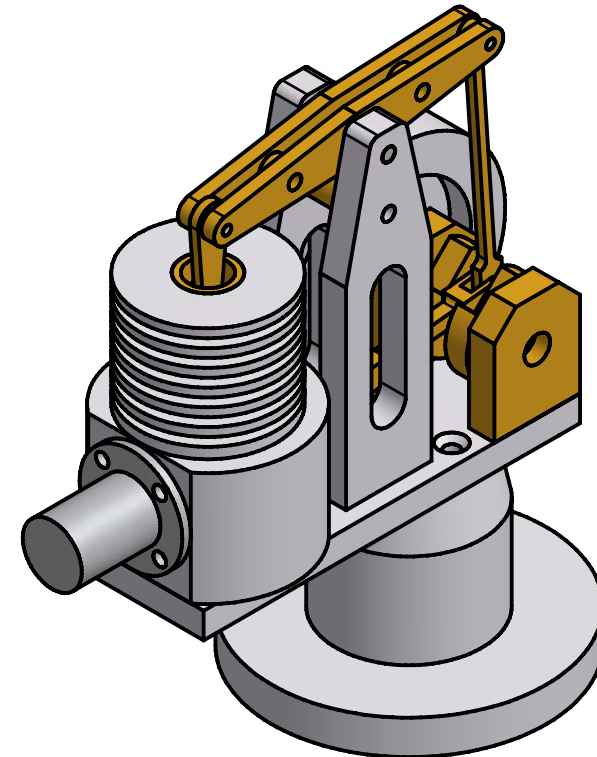

Conçu par JCMA	Vérifié par	Approuvé par	Date	Date 2008-11-16	
			Stirling type alpha	Modification	Feuille 1 / 6

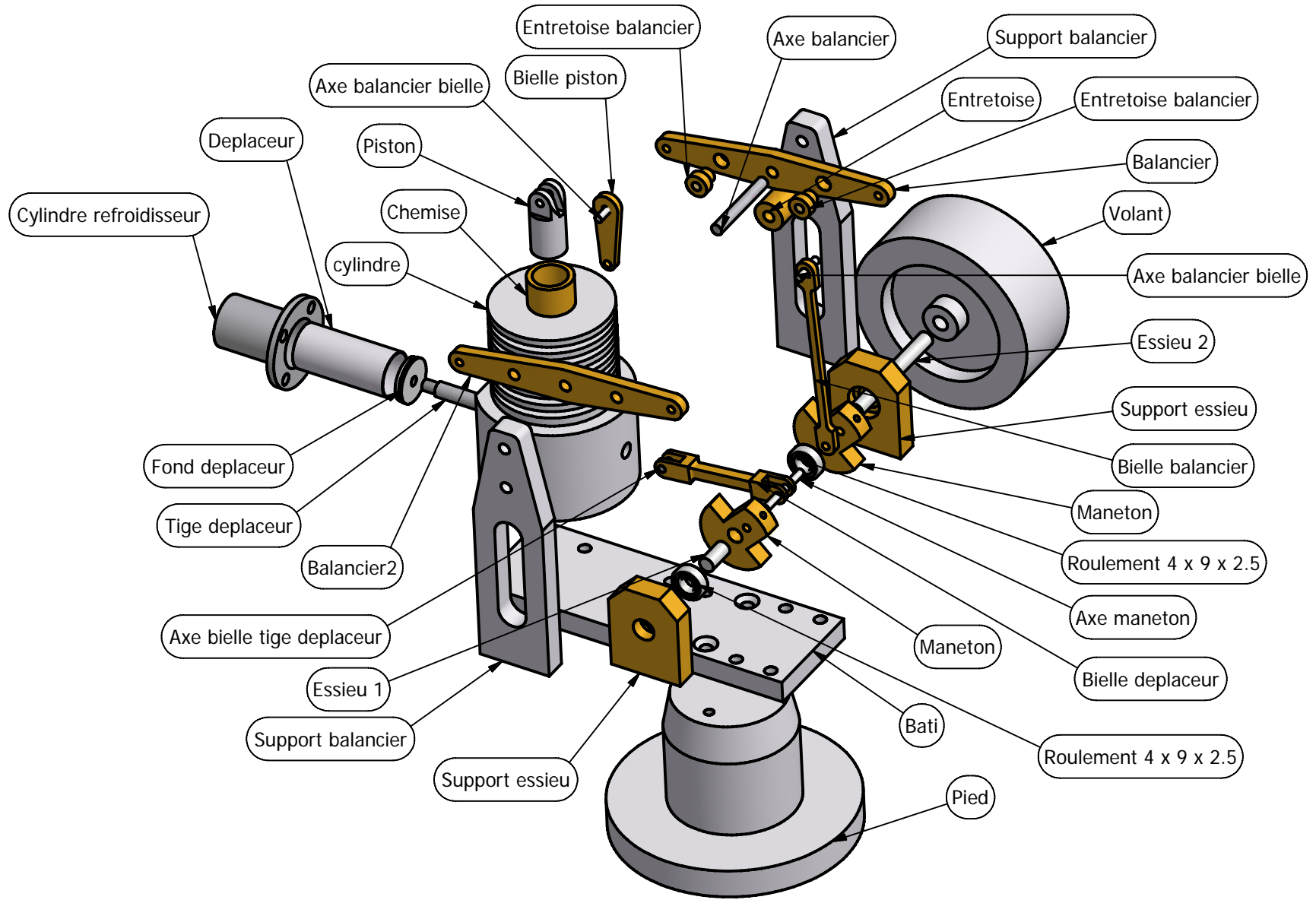

Conçu par JCMA	Vérifié par	Approuvé par	Date	Date 2008-11-16
			Stirling type alpha	
			Modification	Feuille 2 / 6

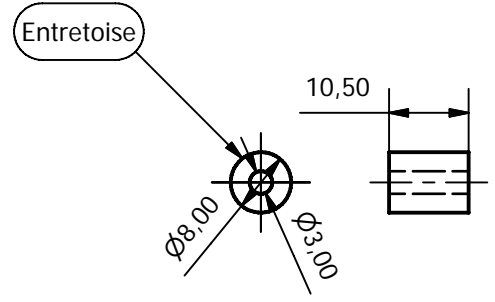
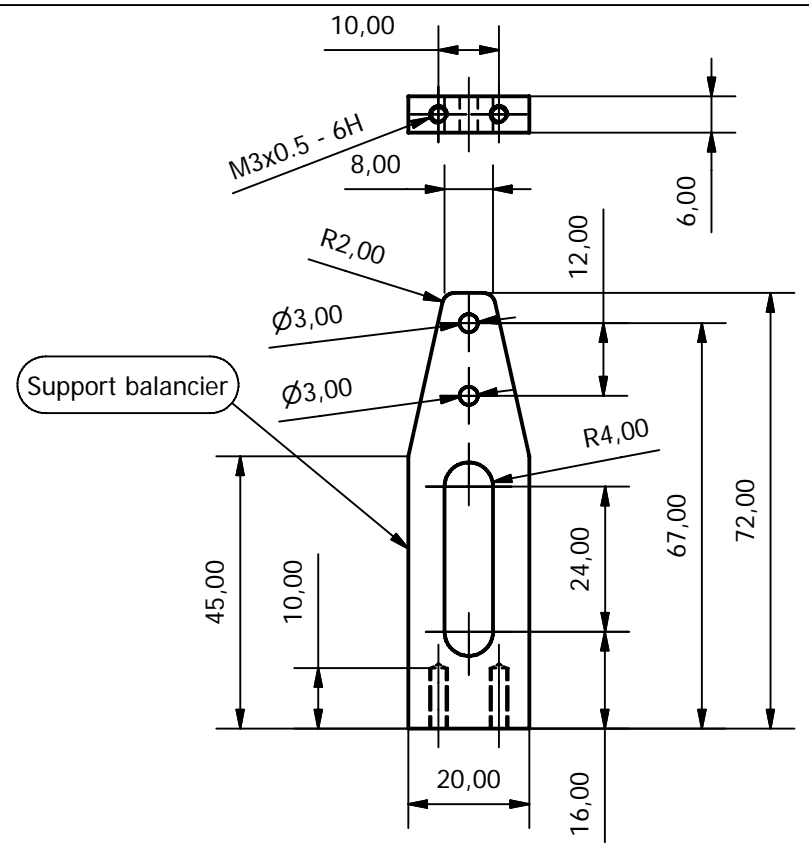
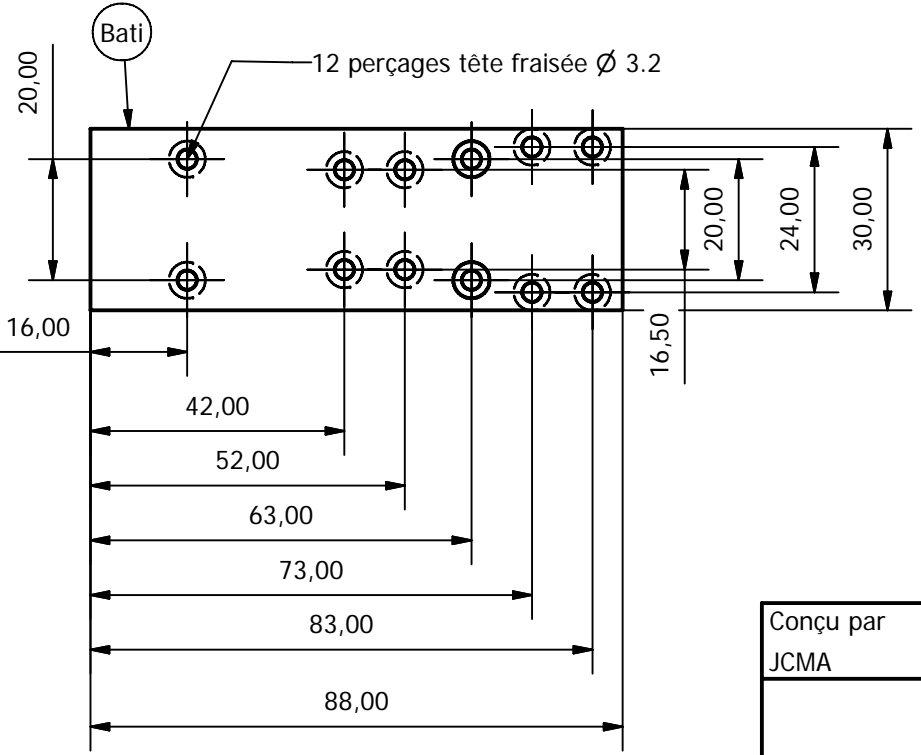
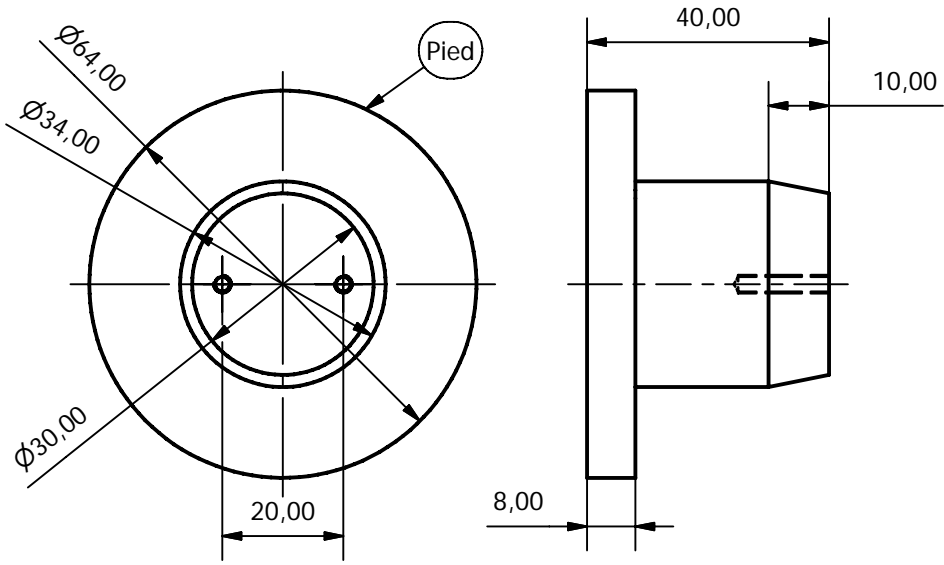

Conçu par JCMA	Vérifié par	Approuvé par	Date	Date 2008-11-16
			Stirling type alpha	
			Modification	Feuille 3 / 6

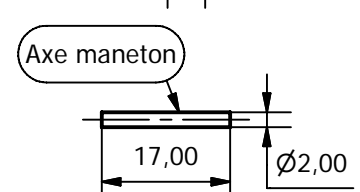
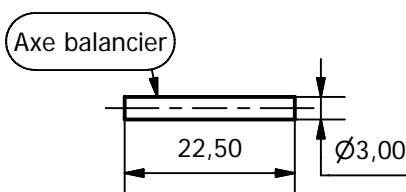
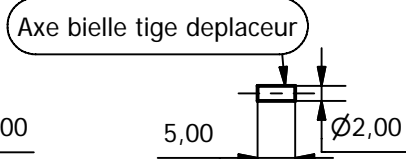
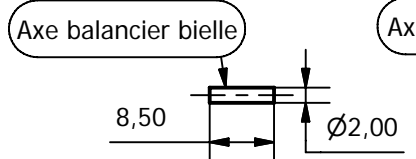
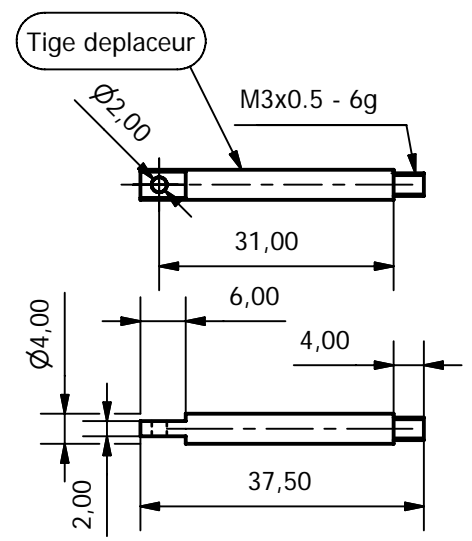
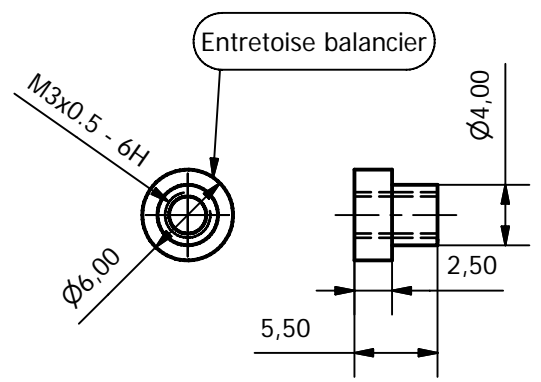
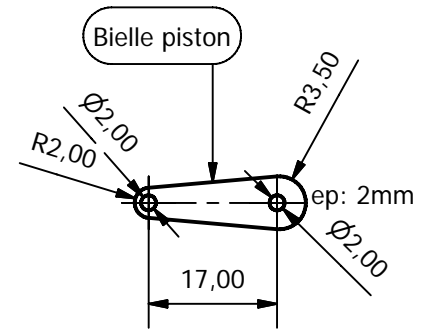
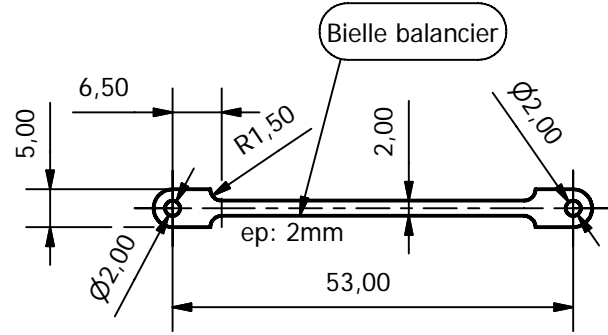
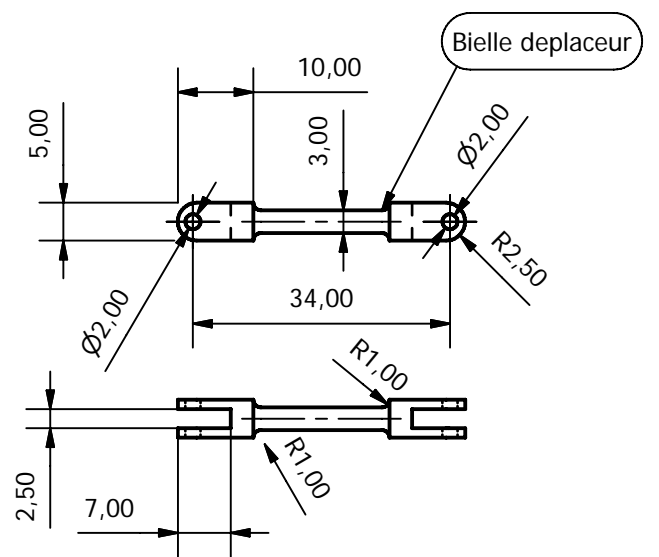
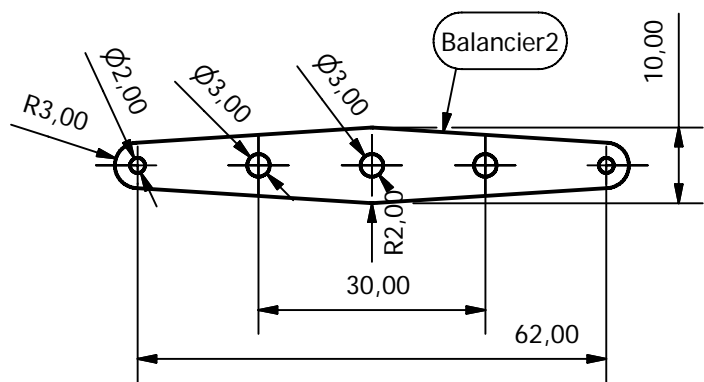
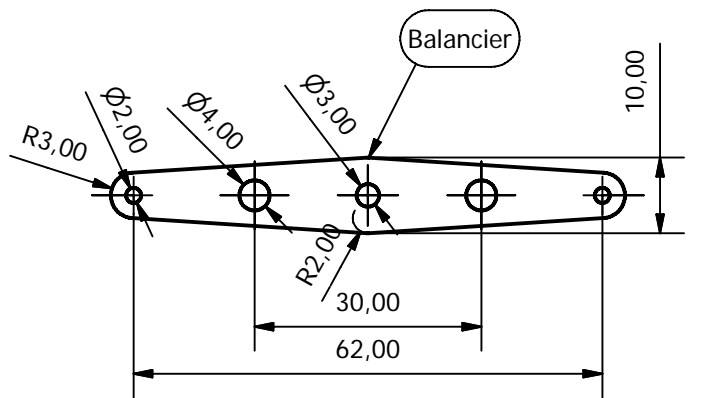

Conçu par JCMA	Vérifié par	Approuvé par	Date	Date 2008-11-16	
			Stirling type alpha		
			Modification	Feuille 4 / 6	

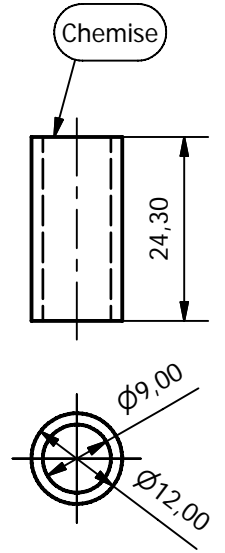
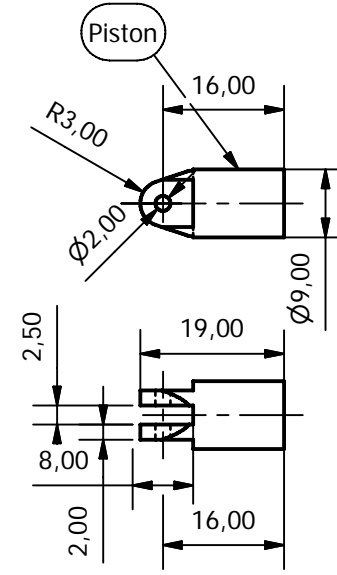
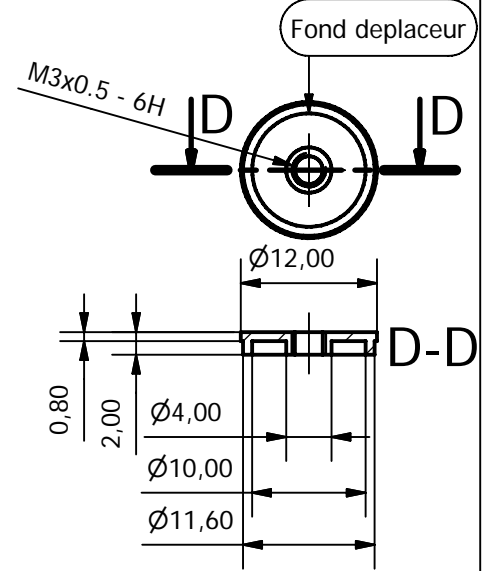
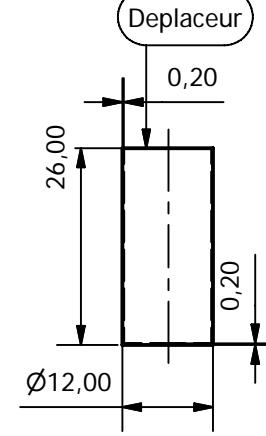
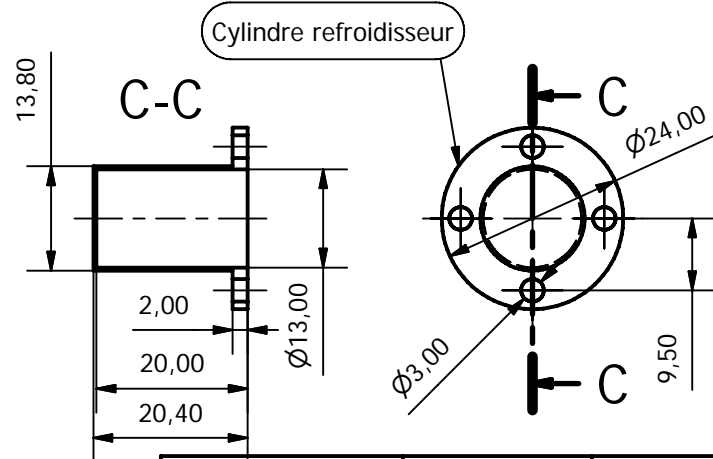
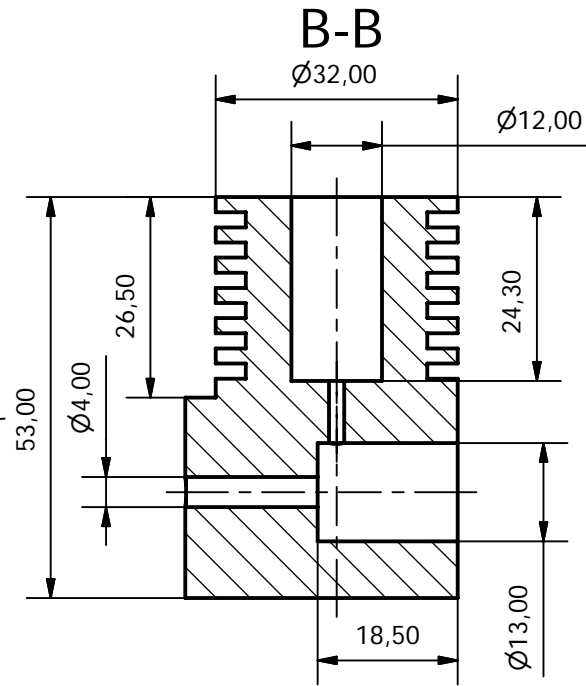
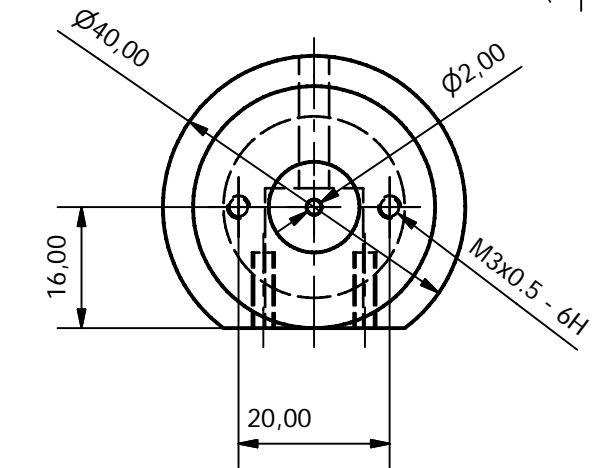
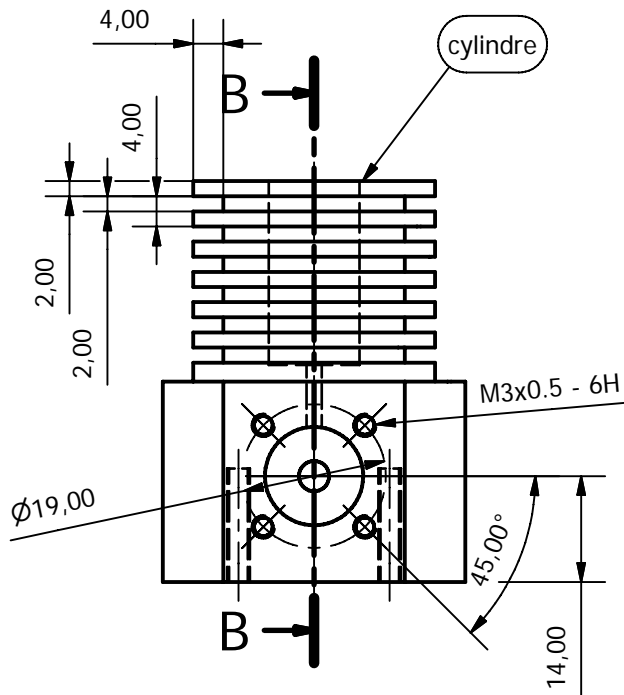

Conçu par JCMA	Vérifié par	Approuvé par	Date	Date 2008-11-16
			Stirling type alpha	
			Modification	Feuille 5 / 6

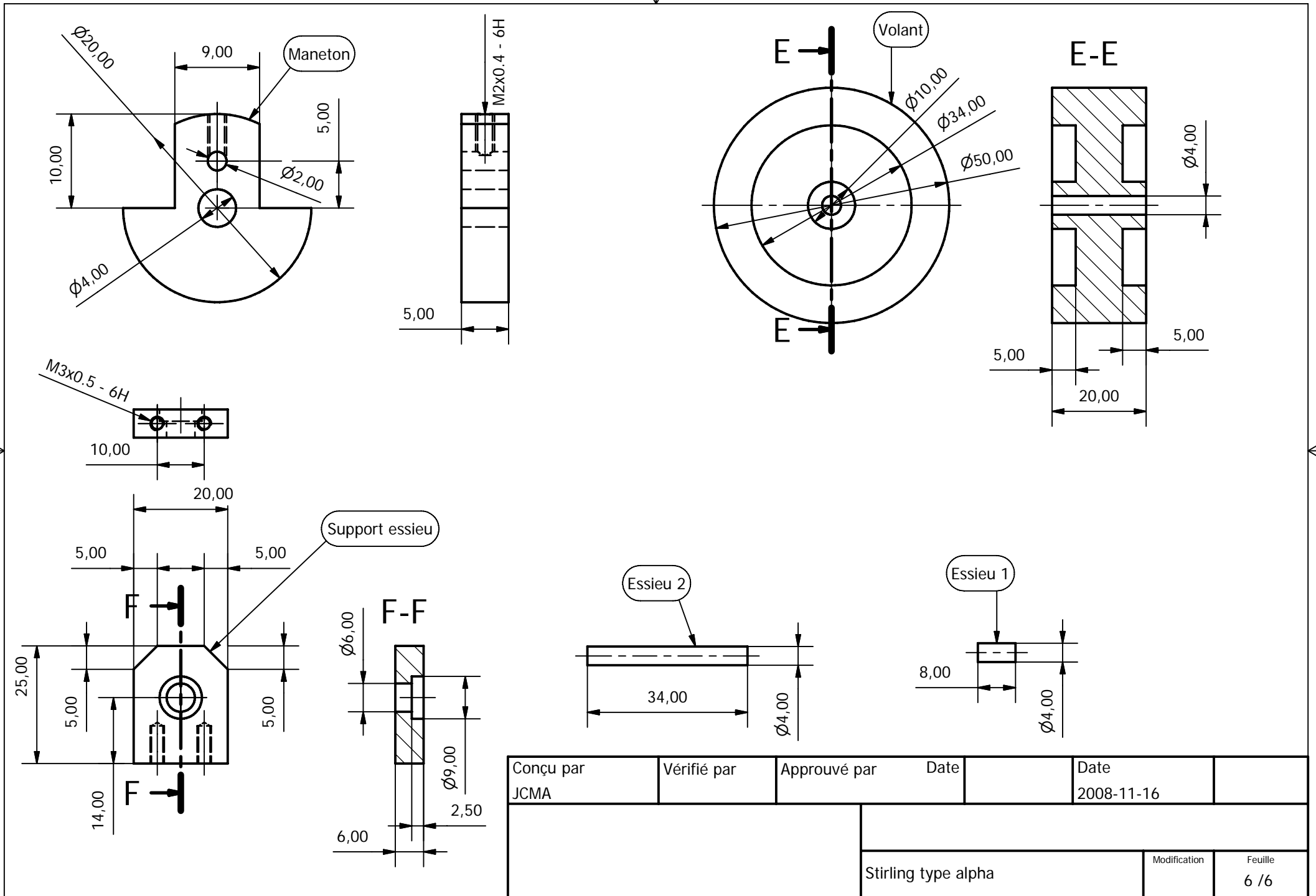

Conçu par JCMA	Vérifié par	Approuvé par	Date	Date 2008-11-16
			Stirling type alpha	
			Modification	Feuille 6 / 6