

moteur à tiroir cylindrique de 1 cm³

« le moteur du tracteur »

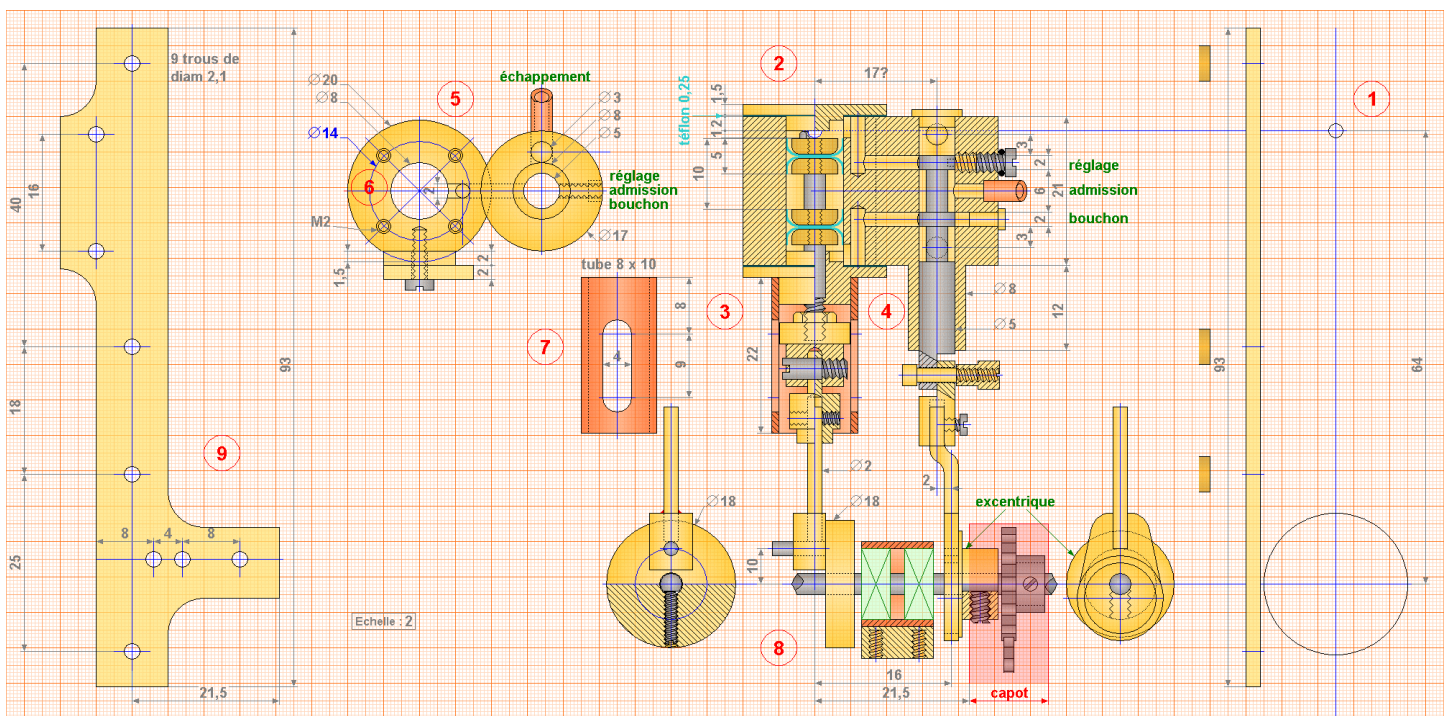

plan d'ensemble

conception Jacques Clabaux – dessins Eric Gauthier

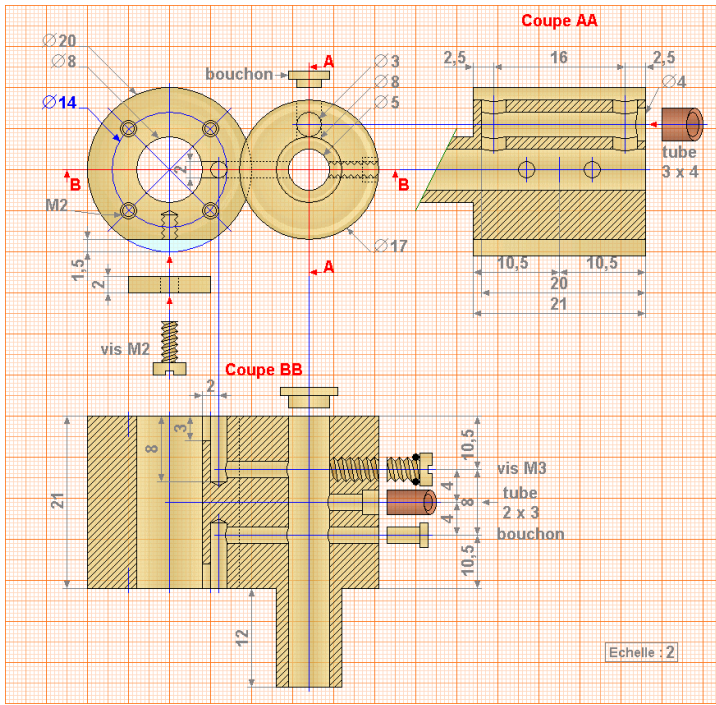

cylindres

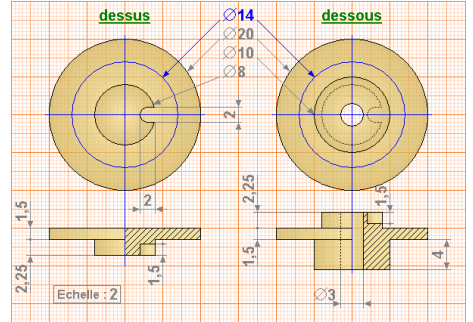

bouchons

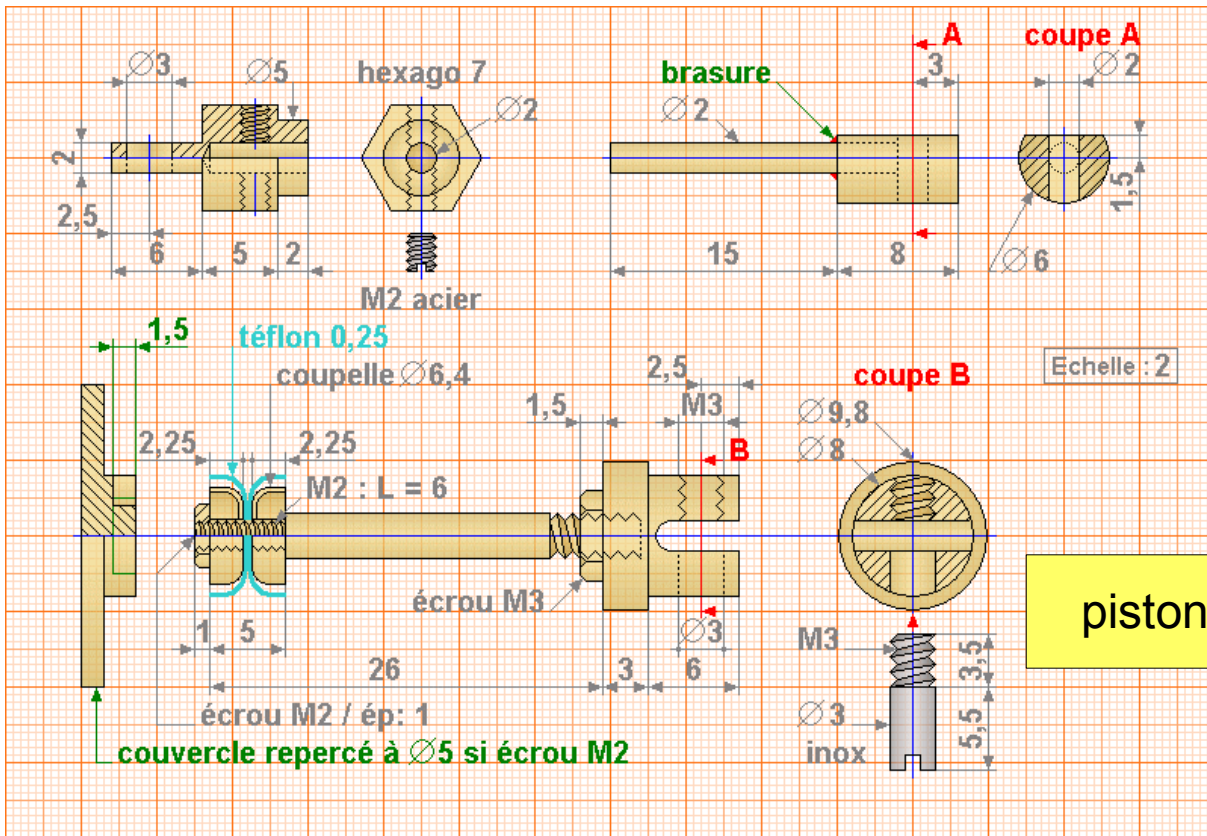

piston et bielle

support des roulements

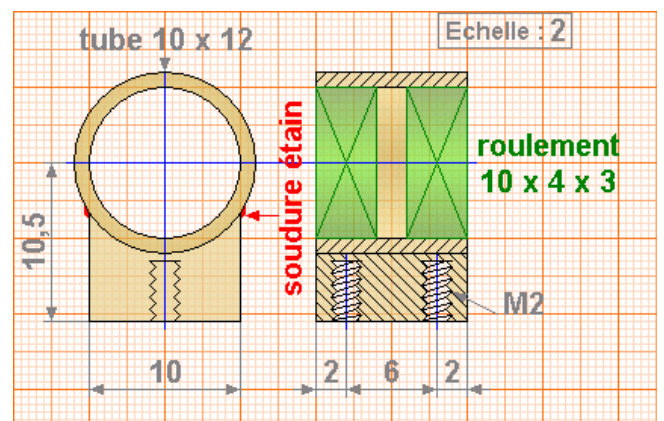

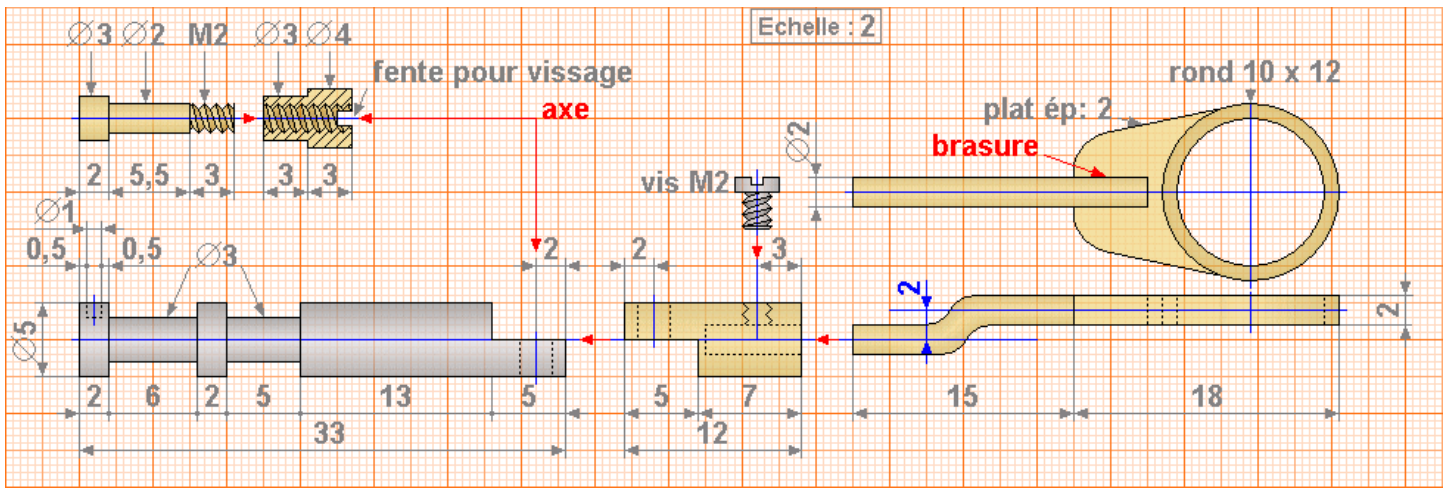

excentrique et bielle

excentrique

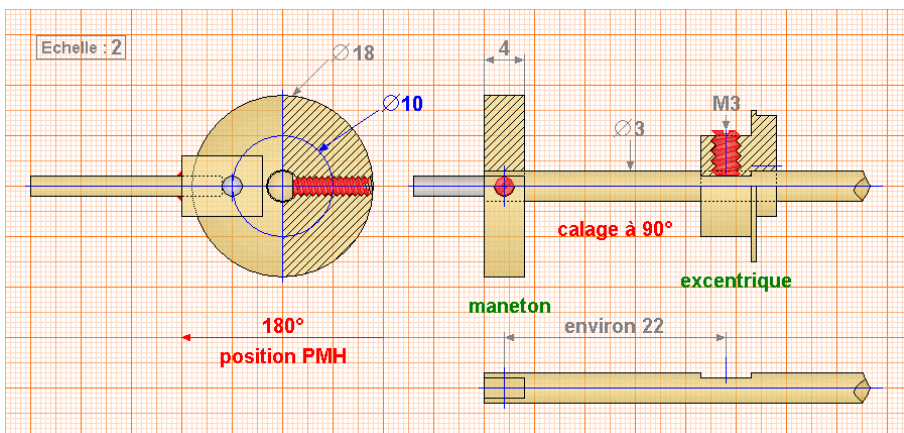
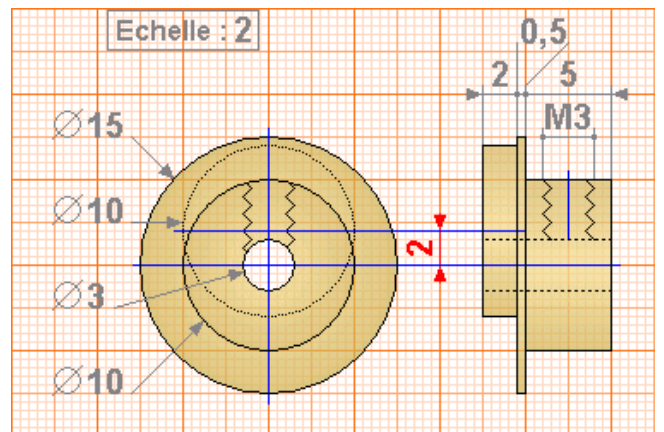

arbre moteur

Trucs et astuces pour la construction sur :
www.vapeuretmodelesavapeur.com