

OLI 321

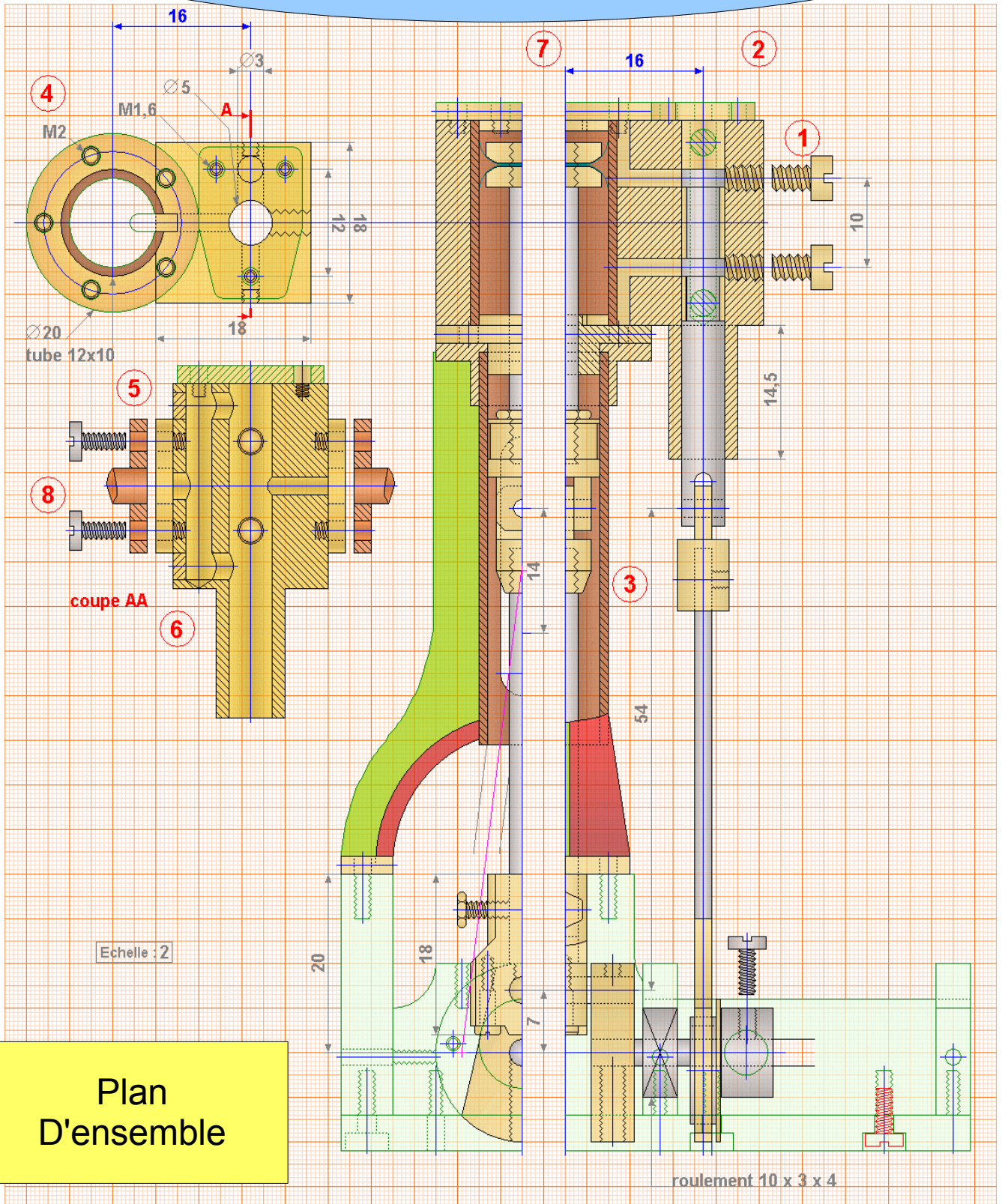

Plan
D'ensemble

conception Jacques Clabaux – dessins de Eric Gauthier

le pied

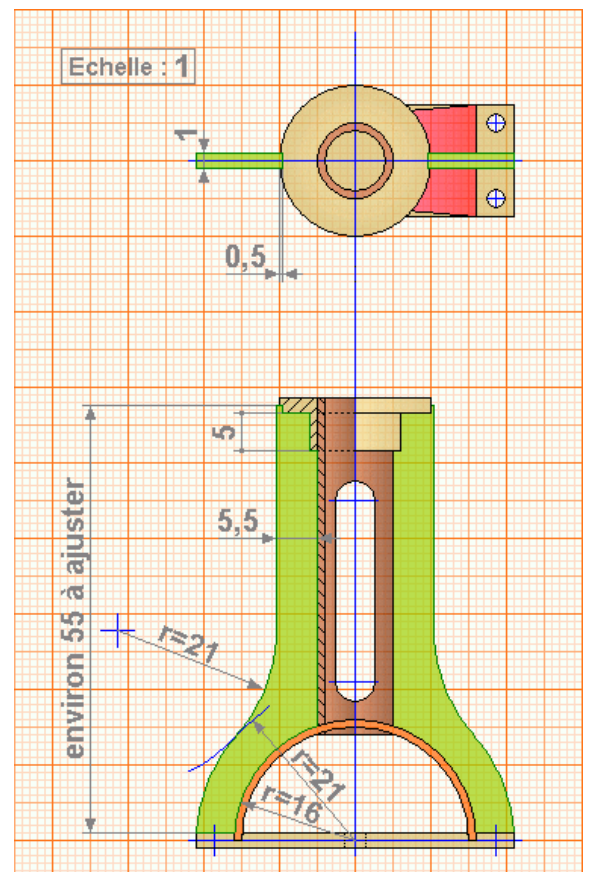
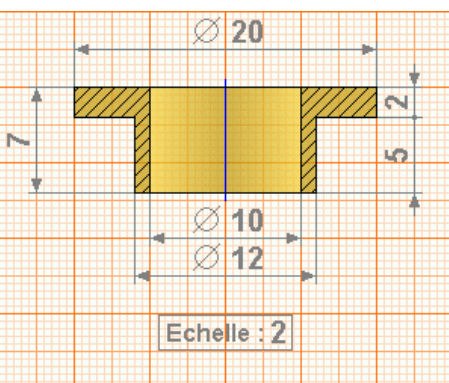
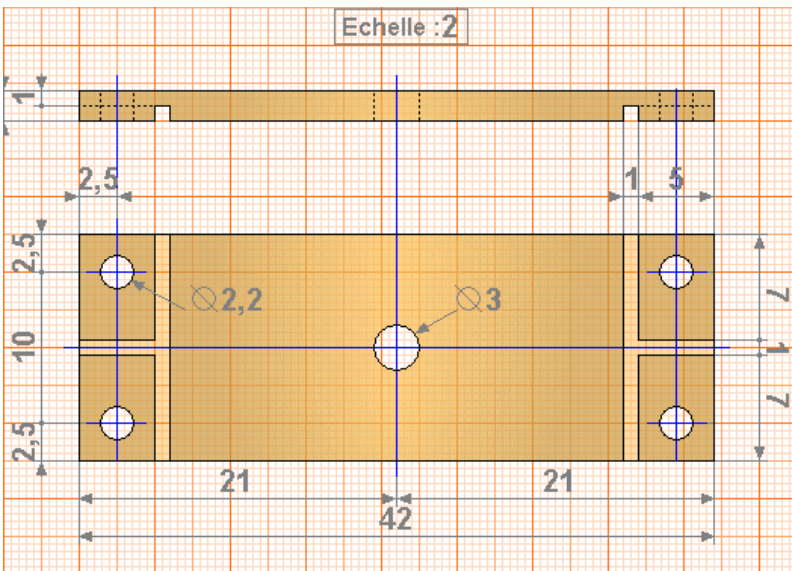
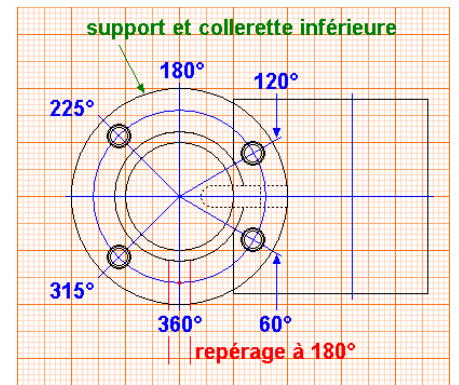
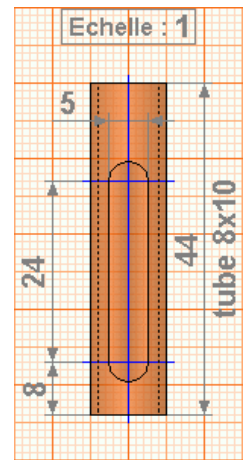
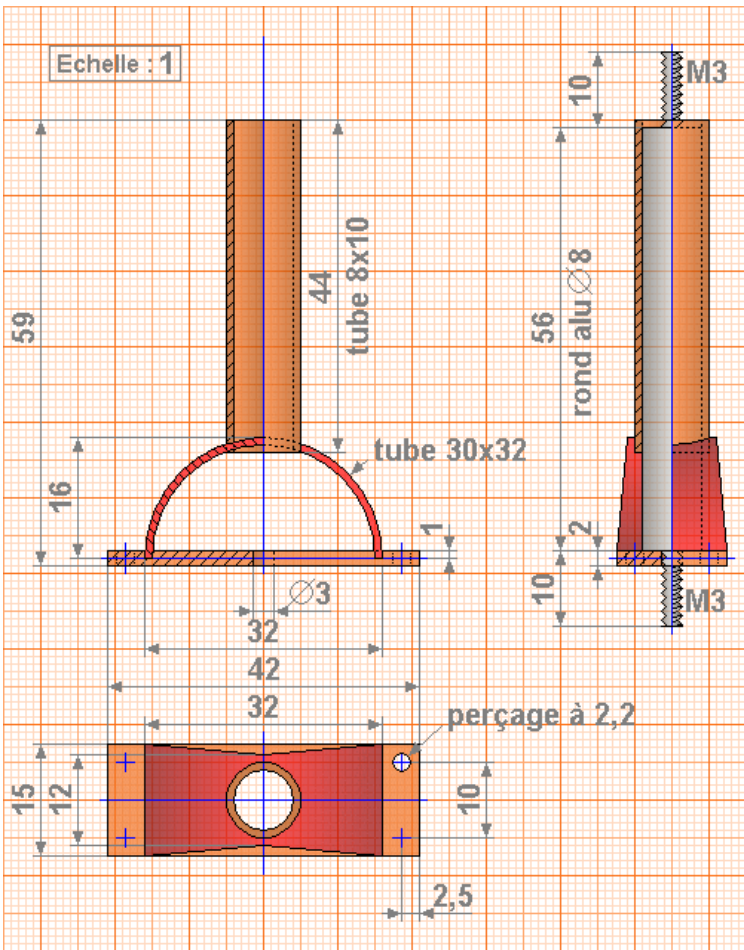

Echelle : 2

côté
alu ép : 6 mm

palier
alu ép : 4 mm

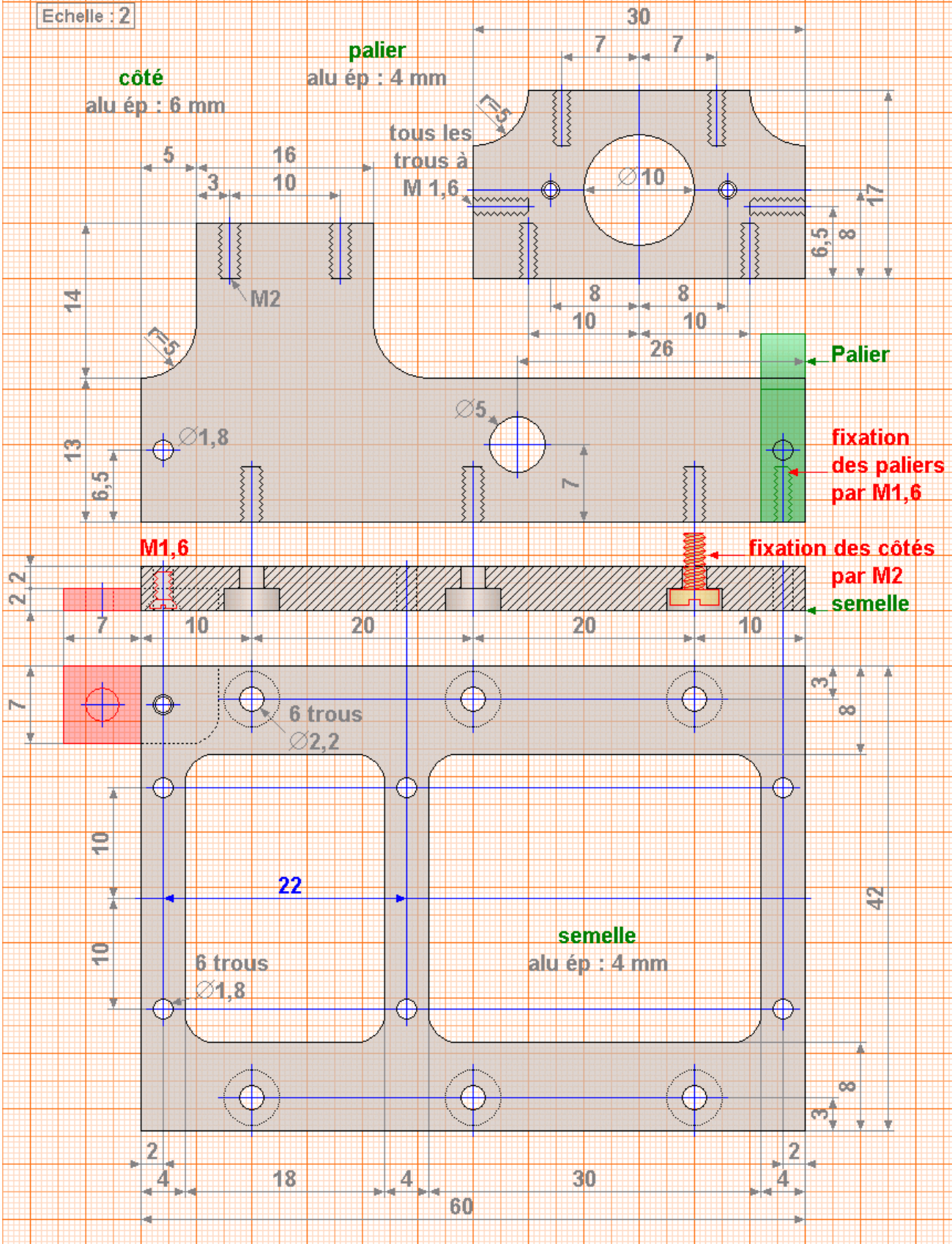

le bâti

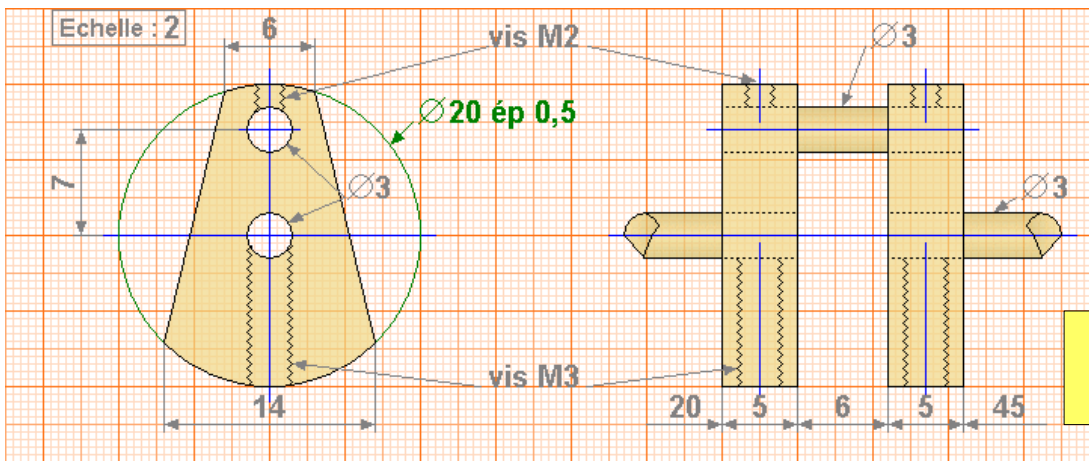

vilebrequin

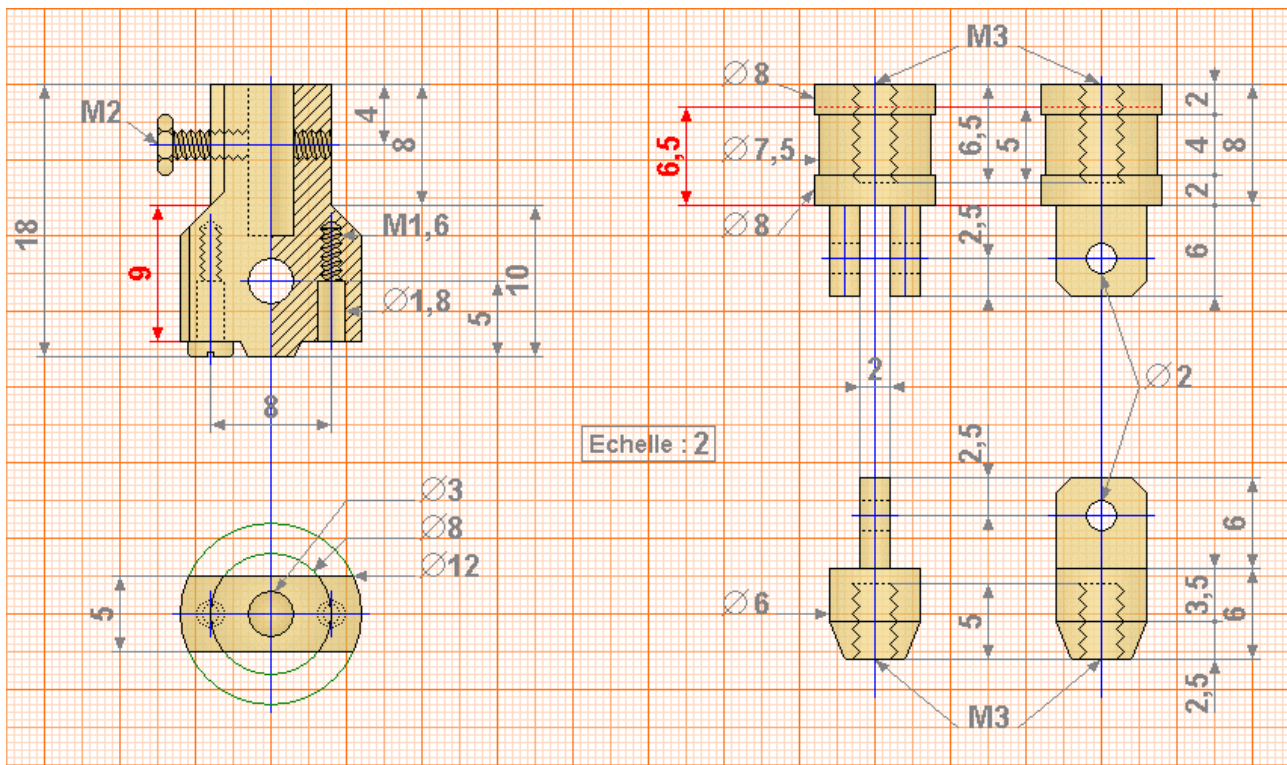

bielle maneton et coulisseau

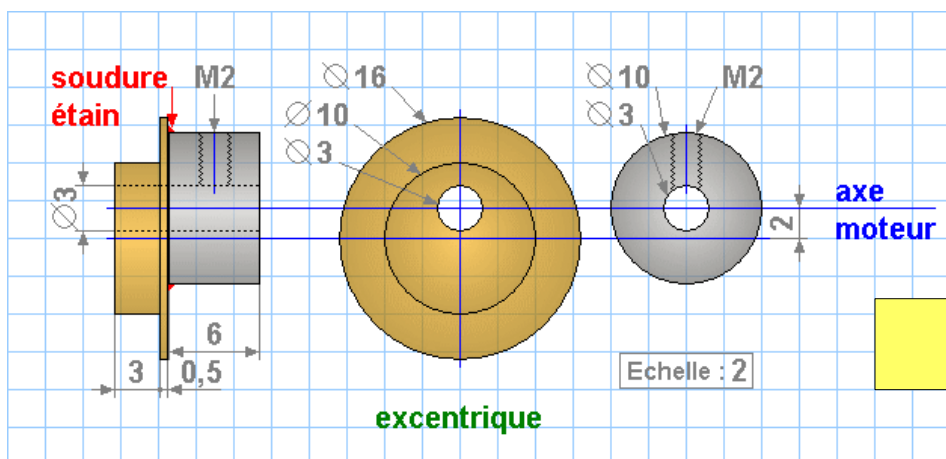

excentrique

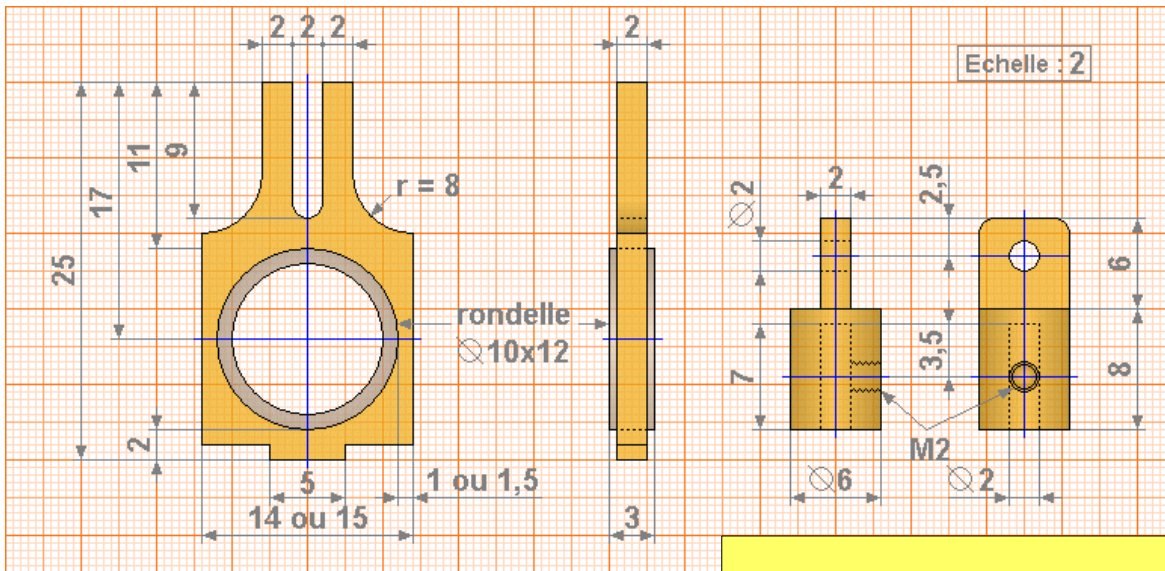

bielle d'excentrique

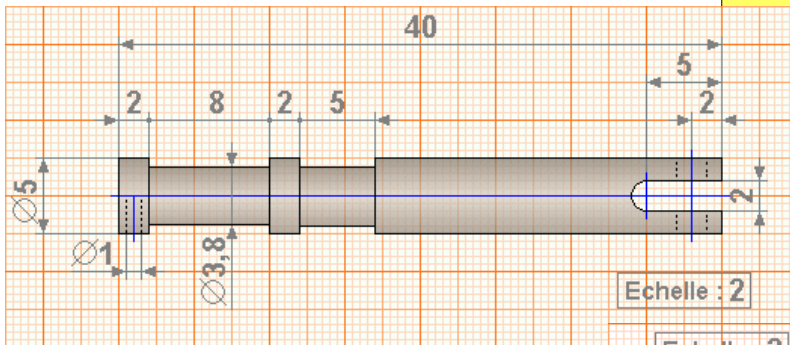

piston

tiroir

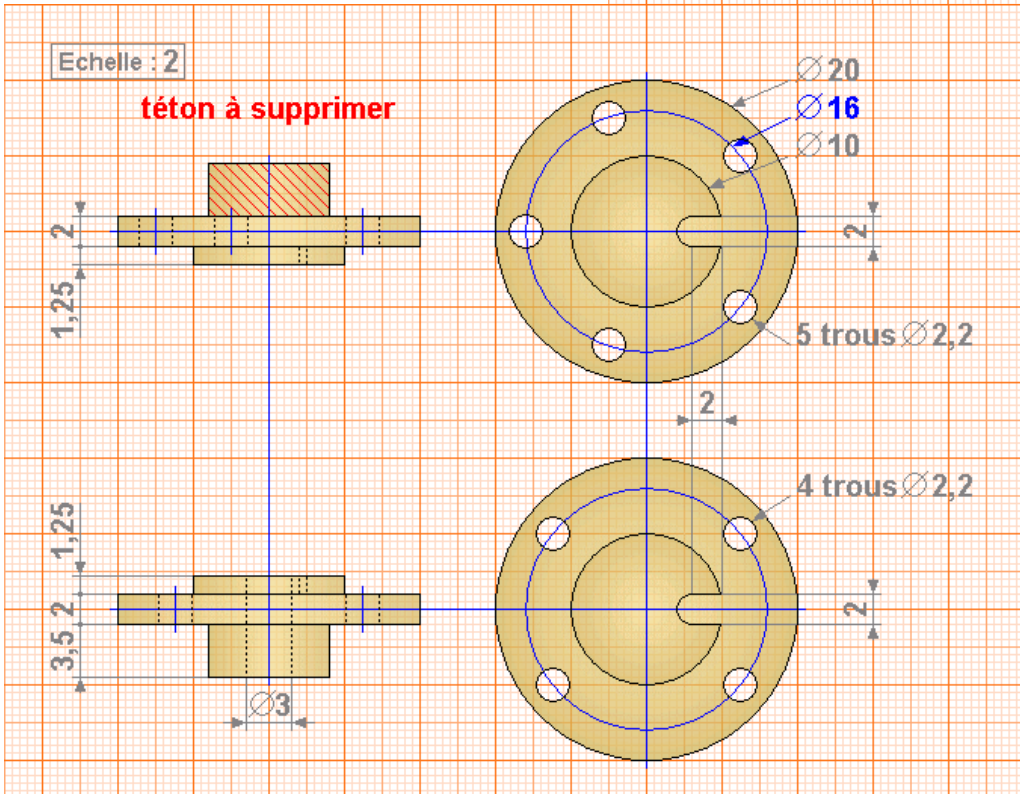
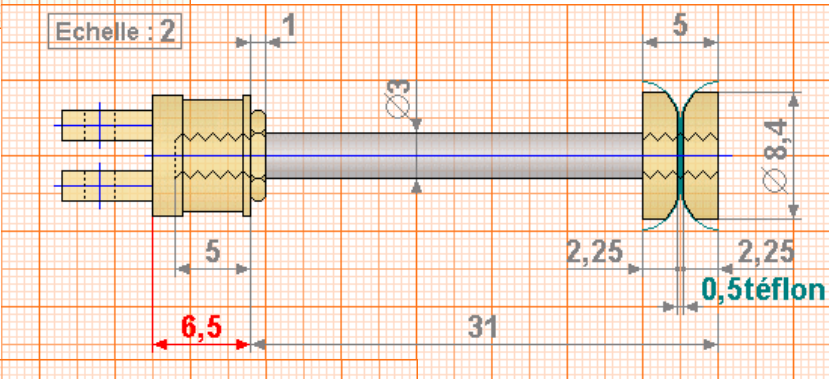

chapeaux

